

AMERICAN UNDERSLUNG



SIX



TYPES 644 AND 642

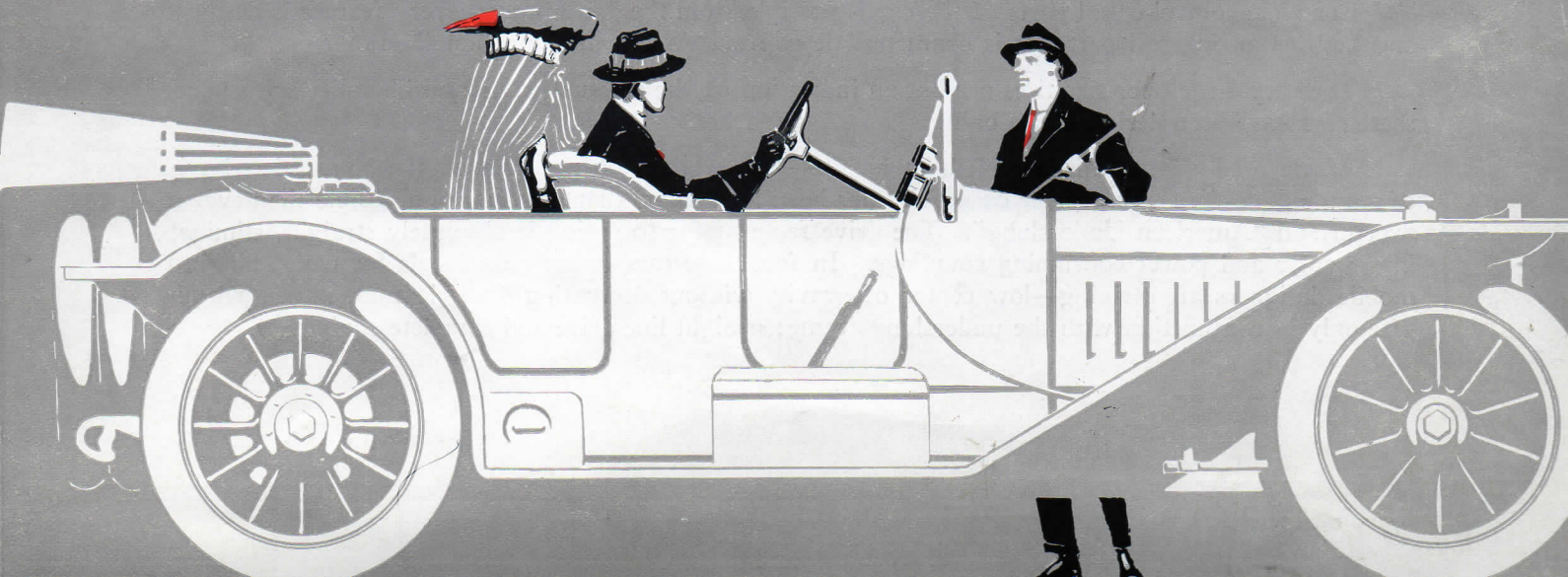

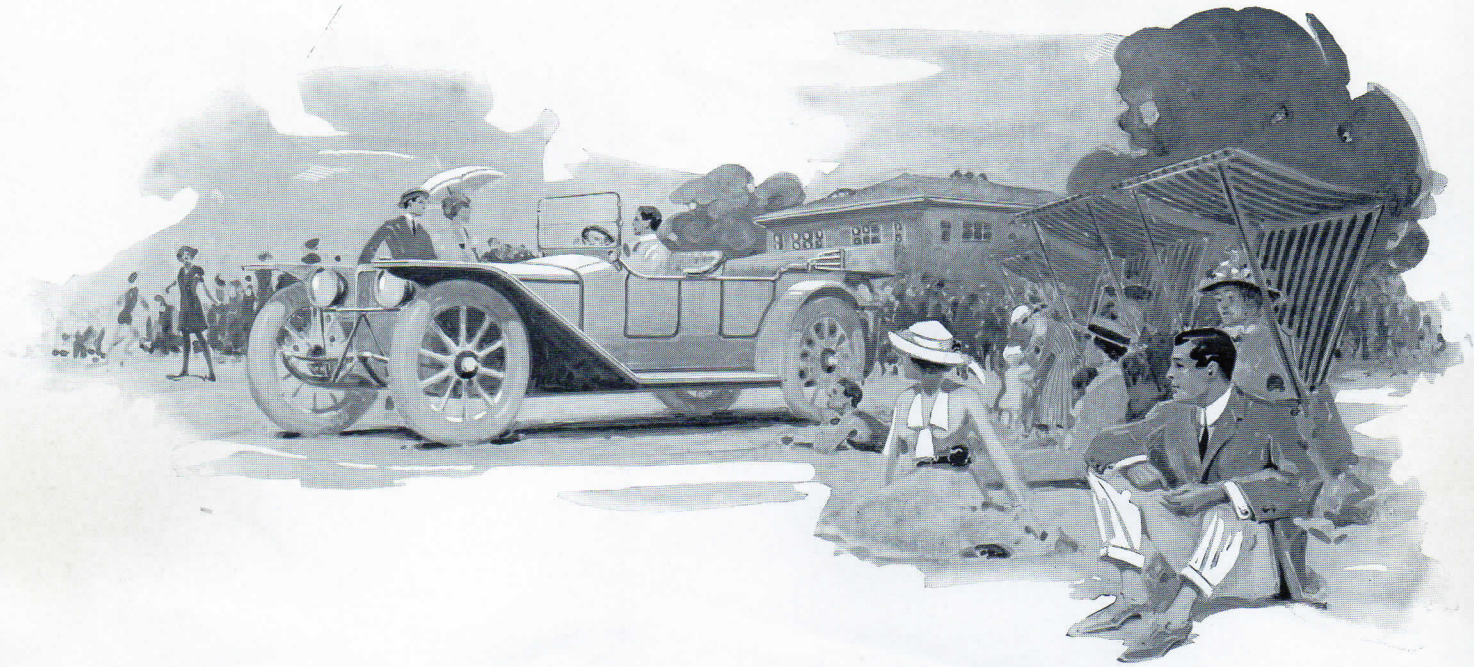

THE REALIZATION OF AN IDEAL

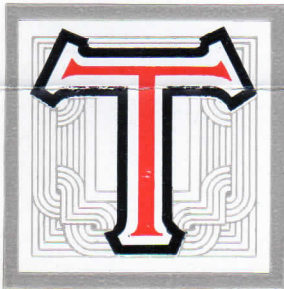

THE "American Underslung Six" is complete, it meets the universal demand for more power with greater economy in gasoline, oil and tires. The quality is undoubted—the same goodness is continued in this model that has long made the name "American Underslung" synonymous with excellence in motor car construction. Distinctiveness and luxury have been the keynote of our endeavors, combined with the manifold merits of the underslung frame and proven six-cylinder construction. Refinement is apparent in every line, true luxury reflected in every detail, and good hard motor sense in every mechanical feature. It appeals immediately to the motorist of taste and occupies the enviable position of a car built to meet the requirements of those who know good motor cars and good motor car construction.

These cars set another mile-stone in the wonderful progress of motor car building.

Nothing is lacking—the powerful and efficient electrical starting and lighting device, as much a part of the car as the motor itself, is but one of the features of true luxury to be found in this car. The long stroke, continuous power, six-cylinder motor is in every sense a six, a "Six" not only in the number of cylinders but a "Six" in flexibility—a "Six" in power at high speed and a "Six" when throttled to five miles per hour in heavy traffic. It is as sensitive and responsive as "Sixes" can be made.

Complete control of all parts of the car is possible from the driver's seat, every feature is designed and built as an integral part. It is characteristic of true "American Underslung" enjoyment.

The very large over-size tires are but an indication of the unusual value and liberality with which these cars have been designed and built.

Ample road clearance is provided, 11 inches—greater than 90 per cent of the conventional type of cars built to-day. The center of gravity has been lowered so that it is more impossible than ever to overturn an "American Underslung." The drive from motor to pinion is absolutely straight, eliminating angular and power consuming couplings. In fact these cars embody the ideals for which all automobile designers are striving—low center of gravity without decreasing road clearance, large wheels, safe only in conjunction with the underslung frame, straight line drive and complete equipment.

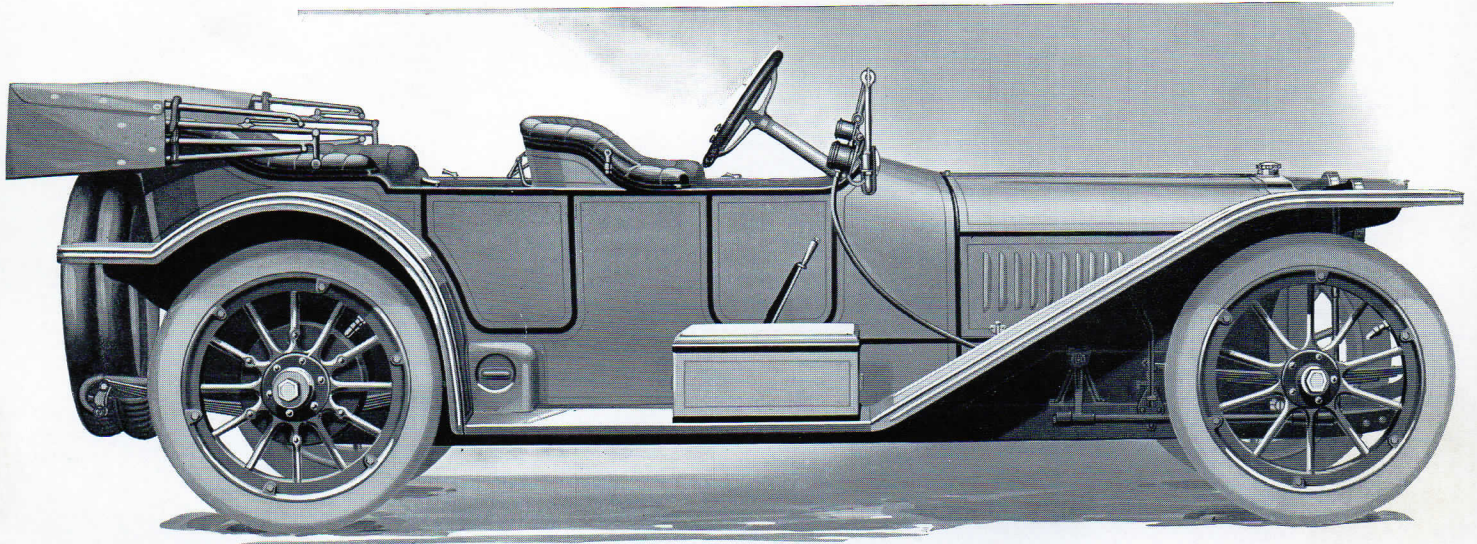

TYPE 644 \$2750 (COMPLETE)

Type 644—a big, roomy, four-passenger car, of the true torpedo type—is ideal for cross-country use or city streets and boulevards. The lines are distinctive but not “flashy”—plenty of luggage space—in fact just the car to answer the demand for the popular four-passenger touring car

Imagine, if you can, the delightful enjoyment of riding on the long 53-inch, semi-elliptic silico-manganese springs—a feature found only in the “American Underslung”

Type 642 is *the* two-passenger car for those whose requirements demand a limited passenger capacity, but at the same time must have all the conveniences of the touring car

A large, commodious baggage compartment is provided, absolutely dust and water proof.

In these cars are combined the supreme effort of our engineers and a most efficient factory organization, using the highest grade materials afforded by the American or European markets. They are presented for the critical inspection of the “knowing” motorist with a feeling of assurance that the verdict will favor the “American Underslung”

AMERICAN MOTORS COMPANY, Manufacturers, Indianapolis.

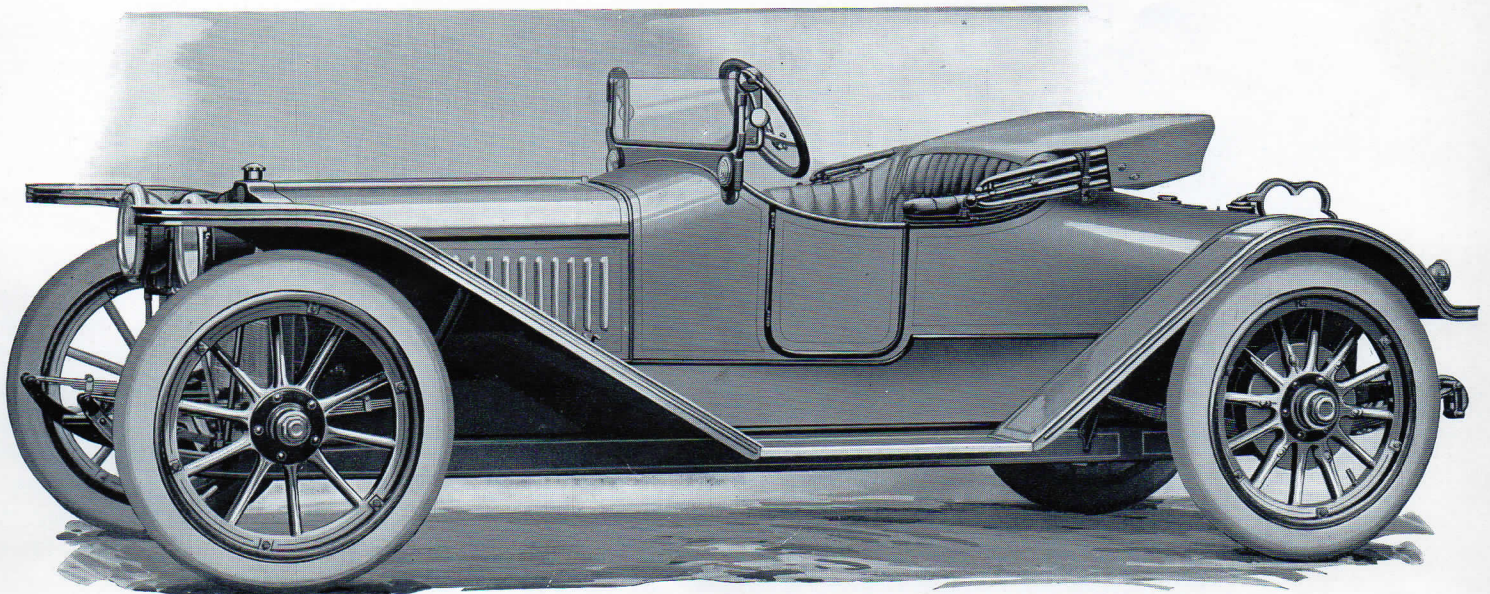

TYPE 642 \$2750 (COMPLETE)

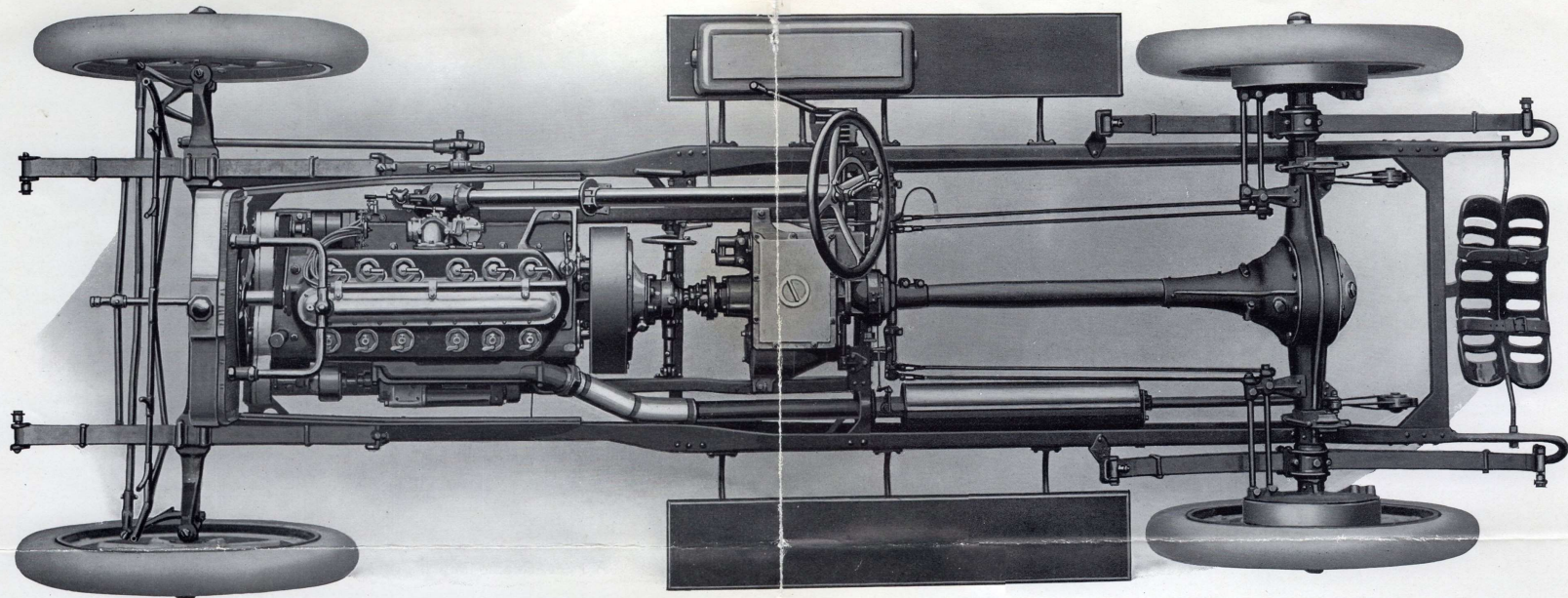

PLAN VIEW OF TYPE "644" AND "642" CHASSIS

Simplicity and accessibility are the dominant features, strongly backed by the unusual sturdiness of every part entering into its construction.

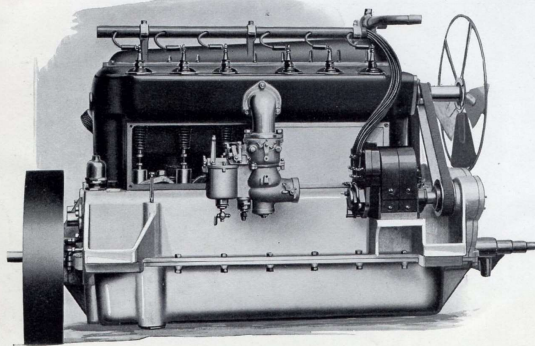

Right side of motor, showing remarkably clean design, and location of magneto. One valve cover removed to expose valve mechanism.

THE six-cylinder "T-head" engine motor, bore 4 inches and stroke 6 inches, is a marvel of power and flexibility. The nominal rating, A. L. A. M., is 38.4 horsepower, but the actual power by dynamometer test is 60 horsepower at 1,600 revolutions per minute. Vibration is eliminated by the perfectly balanced crank shaft and reciprocating parts. Rapid acceleration insured by the large 2-inch valves, long life guaranteed by the four generous bearings in which the crank shaft works and the infinite care and attention given to the fitting of all bearings and grinding of movable parts. The material used throughout is of the best. The same high-grade gray iron is found in the pistons and rings as in the cylinder castings. The crank shaft is drop forged from 45-point carbon steel. Generous water jackets surround each cylinder and valve—the water circulated by a powerful centrifugal pump. Lubrication is positive by the constant level, self-contained splash system and gravity feed to connecting rod bearings.

The powerful and efficient electric lighting and starting outfit is mounted on the left side of the motor and drives through the timing-gears. As a starter it operates at one-twenty-fifth crank shaft speed and as a generator at crank shaft speed. It delivers its maximum output of 20 amperes at 6 volts at a car speed of 12 miles per hour.

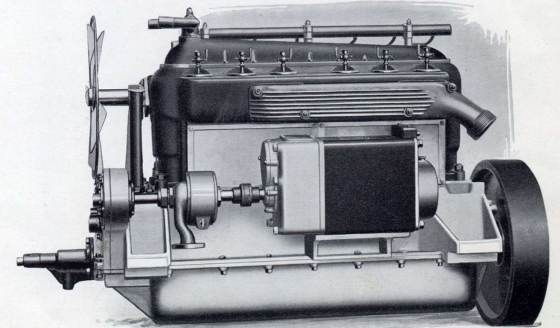

Location of generator-starter on left side of motor. Water pump, housing and bracket for generator cast integral with crank-case. Every moving part enclosed.



FRONT AXLE CONSTRUCTION

Drop forged. Large grease cups provided at all points requiring lubrication. Tie rod and steering arm unusually sturdy.

THE clutch used in the "American Underslung Six" is the result of seven years of constant experiment and development. Seven years of careful experiment to determine proper angularity, spring pressure, diameter and width of face can not have failed to bring this type of clutch to its utmost degree of perfection to-day

The clutch is of the reverse cone type with the female member of cast iron bolted to the flywheel of the motor. The male member or cone proper is an aluminum casting of light weight but great strength, faced with a specially prepared clutch lining of the highest grade obtainable. Six springs inserted in recesses between the aluminum cone and the clutch lining proper insure the easy and smooth engagement of the clutch, and the powerful spring with a pressure of 450 pounds per inch of depression make the chance of a slipping clutch remote indeed.

The clutch proper is supported on a phosphor-bronze bushing of the highest grade, while unusually generous thrust bearings take up the end thrust of the spring and the clutch throwout mechanism.

The four-speed transmission used in this model is an example of the highest type of design worked out in correspondingly high-grade materials and with the best of workmanship obtainable. The gears and shafts in this transmission are of the highest grade alloy steel, all carefully ground to size after receiving the proper heat treatment to insure long life. Every modern convenience in manufacturing as well as the latest engineering data have been brought to bear in making this transmission ideal from the point of silence and efficiency. Take for example the gear reduction, on high speed, the gear reduction at the rear axle is about $3\frac{1}{2}$ to 1, while on third speed the reduction is about $4\frac{1}{2}$ to 1. This makes a very desirable step, affording an ideal high speed, direct drive for fast going on the level—while with the third speed the car is enabled to go from almost a standstill up to 45 miles per hour on a fairly steep grade without any perceptible effort on the part of the motor.

To further insure the silence and long life of this transmission nothing but the highest grade annular bearings of extra generous dimensions have been used throughout. The lubricant is inserted by removing the large cover plate from the top of the transmission, at which time all the gears are readily accessible for inspection.

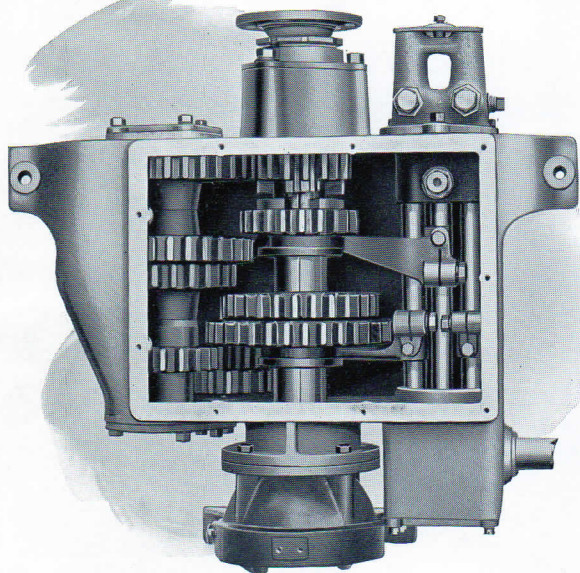

TRANSMISSION

Four-Speed sliding selective type. All gears and shafts, chrome vanadium steel. Highest grade annular ball bearings throughout.

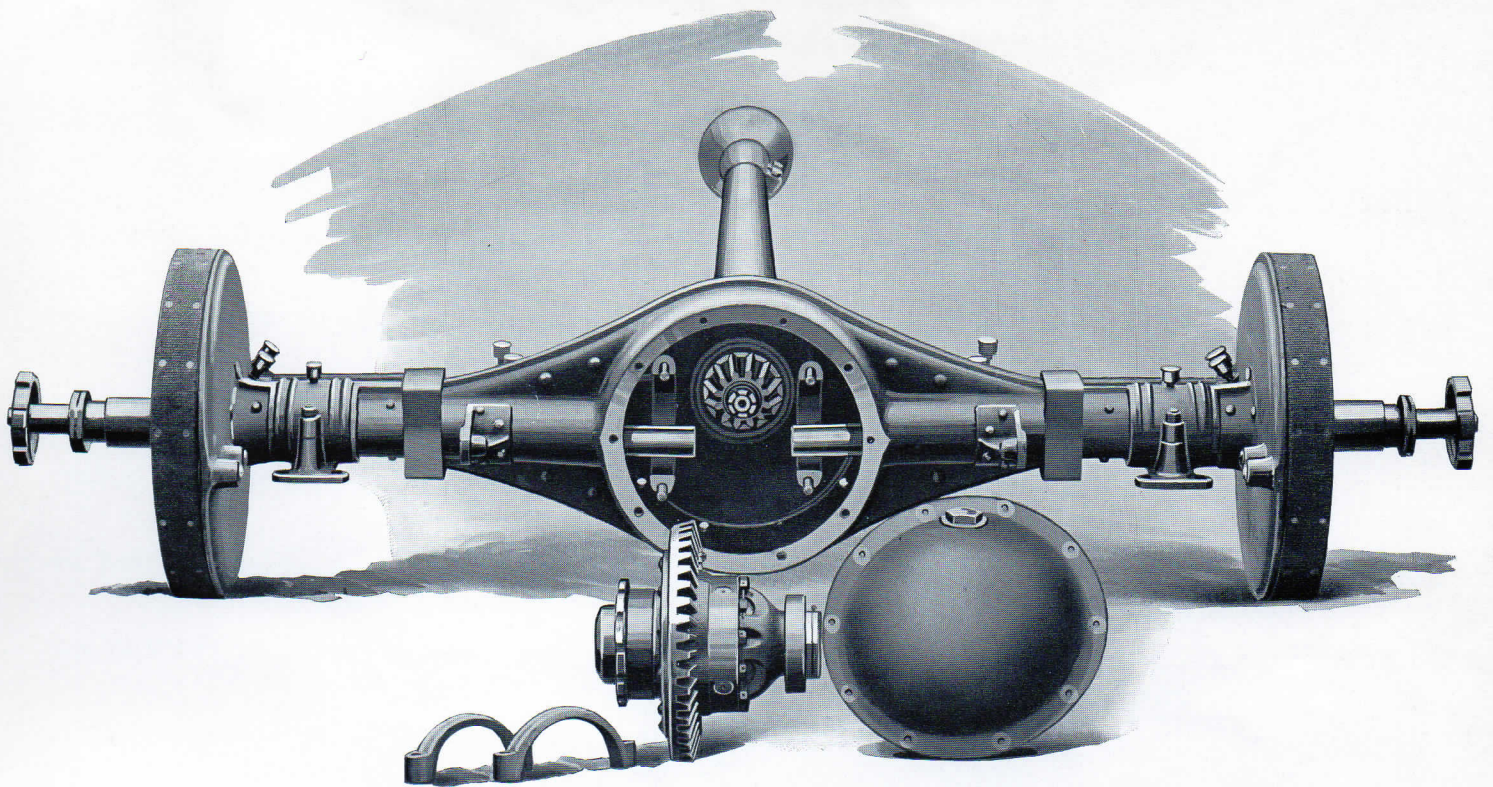

REAR SYSTEM

Accessibility and sturdiness the keynote. Differential may be removed in an instant. Live axles of chrome nickel steel—ring gear $3\frac{1}{2}$ per cent. nickel steel. Axle housing high carbon steel and tubes $3\frac{1}{2}$ per cent. nickel, autogenously welded. Annular bearings throughout.

The rear system used on this model represents the very highest in axle construction known to the industry to-day. The driving pinion and ring gear are made of $3\frac{1}{2}$ per cent nickel steel, carefully heat-treated and ground. The propeller shafts and live axles are of the highest grade alloy steel, more than large enough to take care of any strains which may ever be put upon them.

The axle is of the full-floating type, with all rotating parts mounted on annular ball bearings of generous size, properly lubricated. The drive is through a torsion tube surrounding the propeller shaft terminating at the forward end in a ball enclosing the special "American Underslung" universal joint.

Due to the large diameter, over-size tires, exceptionally large brakes are possible on the "American Underslung" and we have taken advantage of this fact by equipping the car with a brake 16 inches in diameter and 2 inches wide for service or foot brake and 12 inches in diameter by 2 inches wide for the emergency or hand brake. The brakes are of special design, so that 98 per cent of the brake drum surface is made effective upon the application of the brake. The adjustment of the brakes is extremely accessible, being made right at the rear axle. It is only necessary to loosen one nut, turn the brake lever and tighten the nut again in order to secure unlimited adjustment.

Altogether, the "American Underslung Six" represents in material, workmanship, design and attention to details the ultimate realization of modern motor car efficiency and luxury.

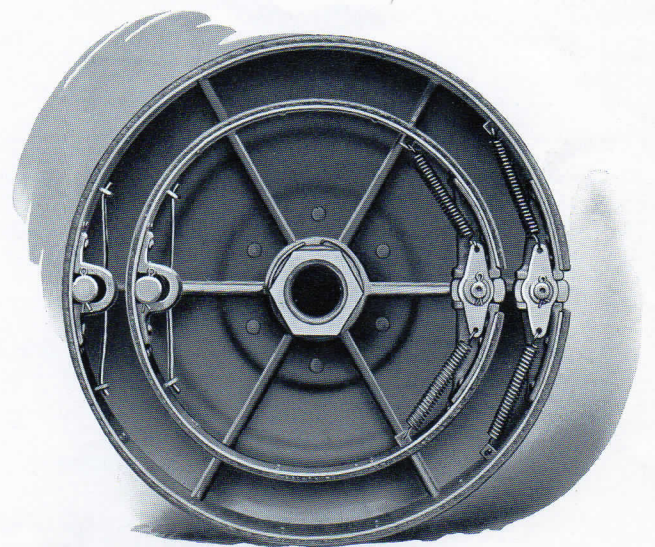

BRAKES

Double expanding on pressed steel drums. Service or foot brake 16 inches in diameter. Emergency brake 12 inches in diameter.

SPECIFICATIONS

MOTOR	Six cylinder, "T" head type, cast "en bloc" Bore 4 inches; stroke 6 inches, valves enclosed with aluminum plate, water cooled by large centrifugal pump; 4-bearing crank shaft, 60 horsepower at 1,600 revolutions per minute.
IGNITION	Dual system, comprising high-tension Eisemann magneto and storage battery, battery being kept constantly charged by the lighting generator
SELF-STARTER	Double unit type electric starter-generator located on special designed bracket cast integral with crank case and operating through unusually broad and specially designed timing gears. The starting and lighting outfit consists of generator, storage battery, automatic cutout, switches, regulator, etc.
LUBRICATION	Special self-contained automatic level, splash system on motor. Sight oil-feed located on dash, transmission and differential run in non-fluid oil.
CLUTCH	Cone type, woven asbestos facing, spring inserts under facing permit easy engagement.
TRANSMISSION	Sliding selective type, FOUR-SPEED forward and reverse, direct on fourth speed. Shaft and gears of chrome vanadium steel.
REAR AXLE	Pressed steel and autogenously welded tubes and differential housing, tubes 3½ per cent nickel, removable plate at rear of differential housing allows ready access for inspection and adjustment. Full floating type, chrome nickel live axles, double internal expanding brakes in 16-inch drums. Gear ratio on high 3.6 to 1.
CONTROL	Right-hand drive and control. Irreversible worm and gear steering gear, spark and throttle levers inside wheel on a stationary sector Foot accelerator
SPRINGS	40-in. front, 53-in. rear, highest grade silico-manganese steel.
WHEEL BASE	132 inches.
TREAD	56 inches.
TIRES	38 x 4½ front and rear on Q. D demountable rims.
BODY	Type 644, four passengers. Type 642, two passengers. Sheet steel on ash frame.
COLOR	Type 644, coach-blue or gray body on gray chassis, black fenders. Type 642, golden-brown body, black fenders, gray chassis.
EQUIPMENT	Includes electric lighting and starting outfit, Warner speedometer and clock, ventilating windshield integral with body, top, top boot and storm curtains, electric horn, robe rail, foot rest, shock absorbers and full tool kit, including one extra rim.
WEIGHT	3,700 pounds, ready for the road.
LIST PRICE	\$2,750.

OUR OTHER MODELS

Type 666 (six cylinders, six-passenger), \$4,500. Type 422 (four cylinders, two-passenger), \$1,550.
Both self-starting and electrically lighted.